

Ditar Memedi

MSc in Civil Engineering
Ss. Cyril and Methodius University in Skopje
Faculty of Civil Engineering
N. Macedonia

Denis Popovski

PhD, Associate Professor
Ss. Cyril and Methodius University in Skopje
Faculty of Civil Engineering
N. Macedonia

Mile Partikov

PhD, Assistant Professor
Ss. Cyril and Methodius University in Skopje
Faculty of Civil Engineering
N. Macedonia

COMPARATIVE STUDY ON HOGGING AND SAGGING MOMENT REGION OF STEEL-CONCRETE COMPOSITE FRAME BASED ON CONSTRUCTION STAGES

Many commercial software are unable to provide an overview of displacement, i.e. internal static quantities, when it comes to composite steel-concrete frames. The problem arises precisely because of the variation of the stiffness of composite beam in the region of positive and negative moments along its length. It is well known that the problem can be solved numerically by modeling the composite beam using a finite element mesh, however dividing the beam into finite elements requires knowing in advance where the bending stiffness change for each beam, which basically explains the idea of this paper.

In this study, the equivalent bending stiffness of composite beam as part of a composite frame is analyzed.

Determination of the region of negative moments is calculated depending on the phase of loading, according to the principle proposed by Wong [8].

Depending on the loading phase, geometrical and mechanical property of the beam as well as the stiffness of connection, different lengths of these regions are generated. Determining the exact values of these regions is in principle a long and complicated procedure and that is why, for example, considering Eurocode 4, at each end, 15% of the composite beam length is suggested as one of the negative moment segments, and the remainder of the span is defined as the positive moment segment, In this study, to investigate the length of these regions depending on the phase of loadings, five composite frames subjected to the same level of loads, but with different levels of rotational stiffness are considered. Moreover, with the help of this method, a comparative analysis was made with the proposals from EN 1994-1-1.

Keywords: equivalent flexural stiffness, semi-rigid connections, rotational stiffness, composite steel-concrete frame beams

1. INTRODUCTION AND MAIN CONCEPTS

The stiffness of the composite frame beam subjected to vertical loadings varies considerably according to whether the section is subjected to hogging or sagging moments. In the hogging region, the slab is subjected to tension, that's why, it's excluded in the overall bending stiffness of composite beams. While in the zone of positive moments, the concrete section together with the steel section contribute to the significant increase in the bending stiffness due to composite effects.

For such variable stiffness along the length of the beam, simplified models to predict an acceptable constant effective beam stiffness that may be used in analyses are proposed by Leon [2].

$$I_{equ} = 0.4I^- + 0.6I^+ \quad (1)$$

Where I^- and I^+ are the effective second moment of inertia of the composite beam hogging and sagging region, respectively.

In reality, the problem in determining this equivalent stiffness arises because it is directly dependent on:

- the geometric and mechanical characteristics of the beam and column of the frame
- the amount of tensile reinforcement
- the initial rotational stiffness of the beam-column connection,
- construction phase and the degree of shear connectors
- the intensity and type of loads, as well as from their distribution along the length of the beam.

A combination of all these parameters and their mutual interaction is a complex task for researchers in the field of composite steel-concrete structures. The procedure proposed by Wong, which in principle defines the region of negative moments of a composite beam, covers most of the above inter-related functional parameters.

2. WONG MODEL ONE ESTIMATION OF POSITIVE AND NEGATIVE MOMENT REGIONS

To determine the actual equivalent moment of inertia of the composite beam, the determined equivalent stiffness of beam-column

connection, R , should be integrated in the mathematical model of composite frame using the procedure according to Wong [7].

The coefficient of connection (R) algebraically is described with:

$$R = \frac{S_j L_B}{EI_{hog}} \quad (2)$$

- S_j – secant stiffness
- L_B – the span of frame
- EI_{hog} – flexural rigidity of composite beam in hogging region

For this purpose, the stiffness coefficient R is first determined, and the other parameter (α_{ws}) is read from the interaction diagrams.

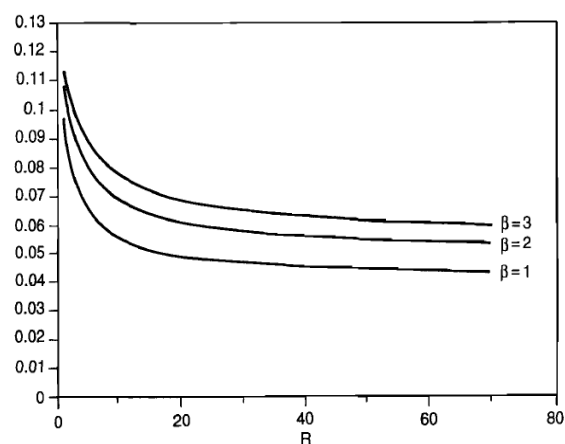

Figure 1. Interaction diagram between R and α_{ws} (Wong,[7])

The diagrams created by Wong are valid if the stiffness of the beam is at most three times the stiffness of the beam over support (bare steel beam).

The curves in this interaction diagram depend on the ratio of the moment of inertia of the beam in the sagging region to the moment of inertia of the beam over the support i.e.:

$$\beta = \frac{I_{sag}}{I_{hog}} \quad (3)$$

2.1 ANALYTICAL MODEL

The moment of inertia in a midspan, for composite beams, is a variable value, i.e., it depends on the loading phase. Accordingly, the bending stiffness also change from phase to phase. It is usual for the stiffness of the beam to be the highest during the short-term loads

phase and the lowest during the permanent loads + yielding phase. From the diagram (Figure 1), a value for the coefficient α_{ws} is read and the following coefficient is determined:

$$\zeta = \frac{1 - \sqrt{1 - 8(0.125 - \alpha_{ws})}}{2} \quad (3)$$

The quantity ζ is known as the coefficient of variation of the stiffness characteristics of the coupled beam. While the value defined by $L\zeta$ describes the region where the beam is in the tension zone. The picture under b) shows a composite beam as an integral part of a coupled frame. In the $L\zeta$ region, the beam is subjected to a negative bending moment. In this area, the steel section and tension reinforcement contribute to the bending stiffness, while the concrete section is neglected in the stiffness contribution.

Combining the region of negative moments with that of positive moments is achieved by determining the equivalent stiffness of the composite beam (Figure 2 under b).

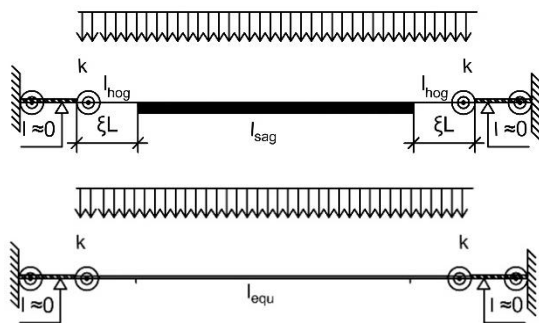

Figure 2. Composite frame beam model -variable stiffness b) composite frame beam model with equivalent stiffness

Equivalent stiffness is calculated as:

$$I_{equ} = \frac{\beta}{(1 - \beta)(1 - 2\zeta)^2 + \beta} I_{hog} \quad (4)$$

With expression [4], compared to Leon [5] expression, a more realistic picture of the stiffness of the composite beam in the composition of a coupled frame is obtained. This is due to the fact that in this expression, the stiffness is given as a function of the secant stiffness S_j , ratio of I_{sag} to I_{hog} , type and intensity of loads, α_{ws} , and finally the region where the beam is in the tension zone, ζ .

2.2 ANALYTICAL MODEL BASED ON EC 4 1994-1-1

To determine the effective width of the concrete composite slab, EN 1994-1-1 treats the beam as a static system: continuous beam of several supports.

Namely, due to the effects of semi-rigid connections, a certain negative moment that would appear near the support would reduce the proposed effective widths of the composite slab.

In the analysis of braced frame structures, a range of parameters should be considered to evaluate the correct width of the composite slab, as well as the region of negative moments. It is evident that EN 1994-1-1 does not reflect the real situation and because of this, Eurocode 4 [4] and GB 50017-2017 [6] recommend 15% of the span between two columns to be taken as a region of negative moments while the rest (70%) of the span, for a region of positive moments.

In the next paragraph, an analytical comparison is first made between the approach implemented by Wong [6] and the above recommendation.

3. COMPARATIVE STUDY

To explain the difference between the proposed procedure and the EN recommended value, in this study, two comparisons are made. The first is a fully analytical procedure based on the classification system for semi-rigid connections proposed by EN1993-1-8 [5] and Chen, W.F, 2011 [2].

The second one is based on the analysis of several frames with semi-rigid connections with different value of connection coefficient R.

3.1 THEORETICAL COMPARISON BETWEEN EC 4 1994-1-1 AND WONG'S PROCEDURE

In order to explain the difference, if the same region is calculated according to Wong's procedure, the expression for (3) is considered as a function of the variable α_{ws} .

From Figure 3 it can be observed that the function $\zeta = \zeta(\alpha_{ws})$ is monotonically decreasing and the minimum of the function $\zeta = \zeta(\alpha_{ws})$ is attained for $\alpha_{ws} = 0.125$. This

means that for $\zeta = 0$, the composite beam is treated ideally as a simple supported beam.

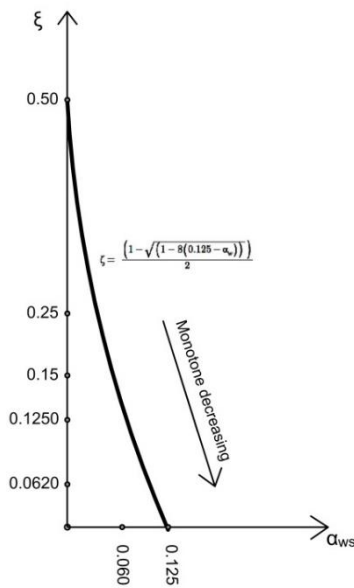

Figure 3. Monotone decreasing function of parameter $\zeta = \zeta(\alpha_{ws})$

The coefficient R, in most cases takes values in the interval from 0.5 to 8 [2].

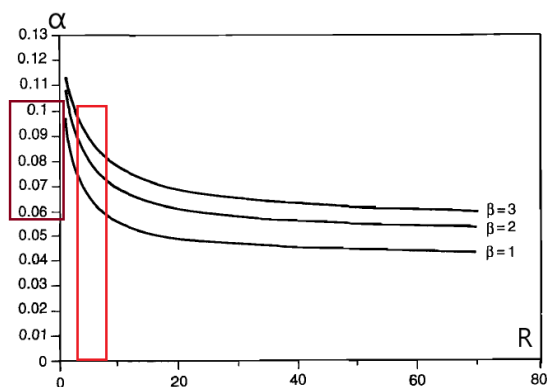

Figure 4. Predicted values for the coefficient α_{ws} based on Chen, [4]

That is, the values for the coefficient α_{ws} are in the interval from 0.060 to 0.100. Using the function $\zeta = \zeta(\alpha_{ws})$, the values for $\alpha_{ws} \in [0.060, 0.100]$ are mapped to the interval presented in Figure 5.

It is worth noting that no matter how small the degree of shear connection value is, the quotient between I_{sag} and I_{hog} , that is, the coefficient β , is a value greater than 1. For these reasons, the interval is set aside for values greater than 0.06.

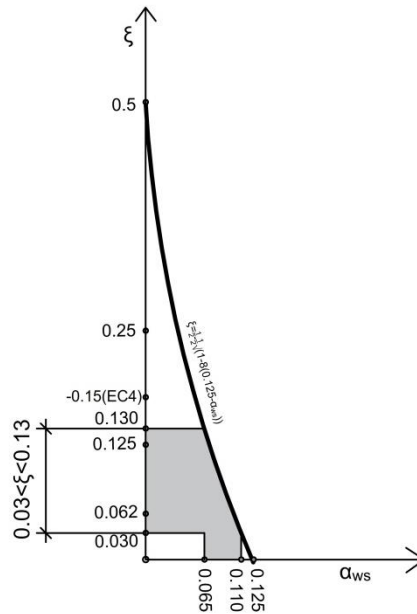

Figure 5. Segment of negative moments as a functional dependence of the parameter α_{ws}

This means that the maximum length of the region of negative moments according to this approach is 13% of the span between two columns.

A value of 0.15, according to this approach, would be obtained if $\alpha_{ws} = 0.060$. From the diagram, such a value for α_{ws} if $\beta \approx 1$ i.e. $I_{sag} \approx I_{hog}$, which means that it is a pure steel beam.

3.2 NUMERICAL COMPARASION BETWEEN THE TWO CONCEPTS

Five one-bay two story braced frames under 12.15 kN/m' gravitational loading conditions are analyzed with the help of Autodesk Robot Structural Analysis 2017. Frames are fixed in the base while the beam-column connection is treated as semi-rigid bare steel connection and its initial rotational stiffness is computed with the help of IDEA StatiCa 21.1 by CBFEM method. The secant stiffness is calculated according to EN proposals, That is, by reducing the corresponding initial stiffness by 50%. The necessary geometric characteristics for solving the frames are shown in a table.

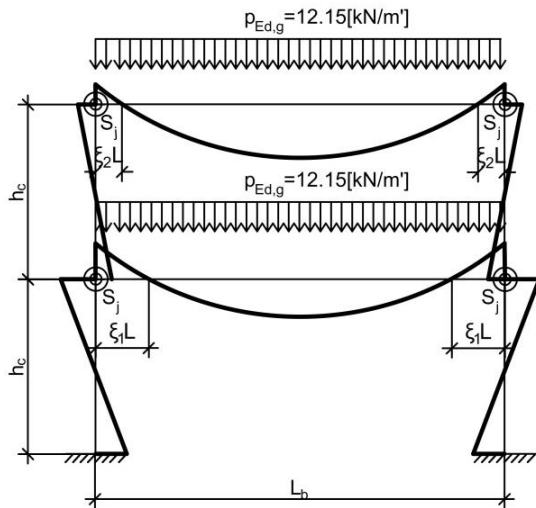

Figure 6. Calculation model

For all frames, an effective concrete section height of 6cm (effective section) above the rib of the profile is taken into account in the analysis.

In **Phase I**, the frame is treated as a bare steel frame with semi-rigid connections. From given loads (12 kN/m') and geometric characteristics of the frames (Table 1), the length of the region of negative moments (ζ') for the five frames was calculated using Robot Structural Analysis.

From the conducted analysis, it is concluded that the lowest value of the region of negative moments was obtained, as accepted, for **Frame 1** in story 2 and its value is $3\% L_B$. For smaller spans, the rotational stiffness of the beam-column connection has relatively low values (in this case $R=0.70$) and it induces small values of the region of negative moments. It can be concluded that the composite frame beam can be treated with high accuracy as a simply supported beam with zero negative moment segment.

On the other hand, for the same frame, for story 1 the region of negative moments it is 6.5%. This is due to the fact that in story 1 we have the continuity of the columns that contribute to increasing the rotational stiffness of the column-to-column connection.

For **Frame 2**, slightly higher values are obtained, ie $8.8\% L_B$ and $6.4\% L_B$ for story 1 and story 2, respectively.

Higher length of the region of negative moments is obtained by increasing the span of the frame and specifically for **Frame 3** with $L_B = 14000$ mm story 1 that value is 10%.

Table 1. Calculated parameters

| | Frame 1 IPE330- HEA220 | | Frame 2 IPE500- HEA340 | | Frame 3 HEA650-HEA450 | | Frame 4 HEA800-HEA450 | | Frame 5 HEA900-HEA500 | |
|------------------------|------------------------------|---------|------------------------------|---------|--------------------------|---------|--------------------------|---------|--------------------------|---------|
| | Story 1 | Story 2 | Story 1 | Story 2 | Story 1 | Story 2 | Story 1 | Story 2 | Story 1 | Story 2 |
| L_b [mm] | 4500 | 4500 | 8000 | 8000 | 14000 | 14000 | 19000 | 19000 | 23000 | 2300 |
| h_c [mm] | 2800 | 2800 | | | | | 5000 | 5000 | 5000 | 5000 |
| S_{ini} [MNm/rad] | 16.20 | 7.70 | 75 | 46.60 | 196 | 104.4 | 457 | 233.80 | 854 | 428 |
| S_j [MNm/rad] | 8.10 | 3.85 | 37.50 | 23.30 | 98 | 52.2 | 228.50 | 116.90 | 427.0 | 214.0 |
| ζ' | 6.8% | 3.5% | 10.6% | 7.5% | 11.4% | 7.8% | 15.2% | 13.9 | 14.2 | 13.1 |
| I_I | 11766 | 11766 | 48198 | 48198 | 175200 | 175200 | 303400 | 303400 | 422075 | 422075 |
| $I_{id,II}$ | 22266 | 22700 | 79230 | 81489 | 260913 | 273496 | 449297 | 453578 | 633591 | 633591 |
| R | 1.47 | 0.70 | 2.96 | 1.841 | 3.72 | 1.98 | 6.81 | 3.50 | 11.56 | 5.79 |
| β | 1.90 | 1.9 | 1.65 | 1.70 | 1.48 | 1.56 | 1.42 | 1.45 | 1.5 | 1.5 |
| α_{ws} | 0.097 | 1.10 | 0.085 | 0.095 | 0.08 | 0.088 | 0.068 | 0.078 | 0.065 | 0.070 |
| ζ | 6% | 3.5% | 8.8% | 6.4% | 10% | 8% | 13.20% | 10.5% | 13.9 | 12.58 |

The obtained values are shown in the table 1. The next step is the analysis of of the frames is **Phase: Permanent loads** in addition of concrete creep effects.

The resulting moments of inertia, $I_{id,II}$ for the corresponding frames of this loading phase are also shown in the Table 1.

Such a value is expected due to the rather large value of the initial rotational stiffness, which is 92 MNm/rad and its corresponding connection coefficient $R=3.72$.

However, also for frame 3 the length of the negative moment region is much lower than the recommended 15% by EN 1994-1-1 [4].

Frame 4 was analyzed. The span is 19,000 mm, while the secant rotational stiffness, according to the calculation using IDEA StatiCA 21.1, is 228.50 MNn/rad, 11.60MNn/rad for floor 1 and floor 2, respectively. The connection coefficient, which equals 6.81 and 3.50 for floor 1 and floor 2, respectively, shows that the connection is in the interval of semi-rigid connections, i.e. both values are smaller than the proposed limit, which is 8.

For this example, it is noted that the length of the region of negative moments for floor 2 has a value of 8% L_B while for floor 1 that value is 13% L_B .

Finally, **Frame 5** is analyzed. The column beam connection in this case has the highest value compared to all previous frames. The semi-rigid connection coefficient for this example for floor 1 is $R=11.56$. Such a value indicates that in this level, the beam-column connection can be treated as a ideally rigid connection, and this is due to the fact that such a value of the coefficient R is beyond the interval of semi-rigid connections proposed by EN 1993-1-8. In the first phase, the length of the region of negative moments, according to the values shown in the table, is 3400 mm (14% L_B) and 2600 mm (10.8% L_B) for story 1 and story 2, respectively.

For story 1, it is evident that the assumption proposed by EN 1994-1-1 of 15% L_B is relatively correct. In the second phase, i.e. in the gravitational loading + concrete creeping effects phase, the length of this region is 13.9% L_B and 12.58% L_B for story 1 and story 2 respectively.

CONCLUSIONS

From the conducted analysis, it can be clearly stated that even for connections that in principle belong to the area of ideally rigid connections, when considering the composite frame beams, due to the high mid-span bending stiffness of

the beam, the region of negative moments obtains value lower than 15% L_B .

It should be noted that if the analysis for the determination of these regions is carried out with the secant rotational stiffness of a semi-rigid composite connection, even lower values of these segments should be expected.

On the other hand, completely neglecting these regions, that is, treating the adjacent beams as an ideally pinned connection, has negative consequences in the beam-column connection itself. Namely, the partial negative moment, which in reality exists due to the rotational capacity of connection itself, is in reality transferred from the beam to the column. If this quantity is not taken into account, it is possible to have negative side-effects on the load capacity of the column itself.

REFERENCES

- [1] ANSI/AISC 360-10, AISC Committee, Specification for Structural Steel Building; American institute of Steel Construction: Chicago.
- [2] Chen, W. F. and Lui, E. M. „Stability design of steel frames“ CRC Press, 1991. Eurocode - Basis of structural design.
- [3] EN 1993-1-1: Eurocode 3: Design of steel structures – Part 1-1: General rules and rules for buildings, CEN 2005.
- [4] EN 1994-1-1: Eurocode 4: Design of composite steel and concrete structures – Part 1: General rules and rules for buildings, European Committee of Normalization.
- [5] EN 1993-1-8: Eurocode 3: Design of steel structures – Part 1-8: Design of joints, CEN 2005.
- [6] GB 50017-2017: National standard of the People's Republic of China UDC.
- [7] Y.L. Wong, T. Yu, S.L.Chan. „A simplified analytical method for unbraced composite frames with semi-rigid connections“ Jurnal of Constructional Steel Research, 63(2007), 961-969.
- [8] Y.L.Wong, S.L.Chan, D.A.Nethercot: „A simplified design method for non-sway composite frames with semi-rigid connections“, The Structural Engineer, Jurnal of the Insitution of Structural Engineers, 1996, 74(2):23-8.