

### **Denis Popovski**

PhD, Associate Professor  
University “Ss. Cyril and Methodius”  
Faculty of Civil Engineering – Skopje  
popovski@gf.ukim.edu.mk

### **Mile Partikov**

PhD, Assistant Professor  
University “Ss. Cyril and Methodius”  
Faculty of Civil Engineering – Skopje  
partikov@gf.ukim.edu.mk

### **Damjan Denkovski**

MSc Civil Engineer  
denkovksidamjan@yahoo.com

## **PULL-OUT TEST FOR MECHANICAL ANCHORS**

In this paper, test procedure and results obtained from experimental research for tension loaded post - installed mechanical anchors are presented. Before conducting the test procedure, additional material for expected type of failures is analyzed according to available literature and standards for calculation of concrete and steel structures, for further analysis of obtained results for the behavior of this type of anchors installed in non-reinforced concrete. Non – standard test of post – installed mechanical anchors loaded with tension force is conducted in non- reinforced concrete, where anchors are embedded according to rules and recommendations given from anchor manufacturer. Results from conducted tests are given in form of load-displacement diagram curves which defines the type of anchor failure. Obtained results are basis for further experimental researches.

**Keywords:** post-installed anchors, pull-out test, mechanical anchors, load-displacement

### **1. INTRODUCTION**

Design of construction and construction elements have to comply with the current norms and standards. In case when the design of structure or detail cannot be in accordance to national norms and standards, then technical approvals should be used. The technical approvals are based on results from qualifications tests conducted by independent laboratories. Modern technology for fastenings is more applied worldwide and every type of anchor is designed for use in special (individual) conditions, such as different type of concrete, load, frequency of load, position of installment etc. If the anchor is not properly installed in conditions which is suitable for, then the safety of the detail is suspected, even the safety of the whole structure. Due to the complexity and diversity of post – installed anchors, all attempts to standardize anchor products have failed.

In the countries in the European Union, calculation of load capacity of anchors is carried out according to Annex C of ETAG001 (Guidelines for European Technical Approval of Metal Anchors for use in concrete) until implementation of CEN/TS 1992-4 (2009) as part of Eurocode 2 (2005) – Part 4. In United

States calculation for load capacity of anchors is regulated from 2002 in Appendix D from ACI318 (2002), revised and supplemented in 2011. Recommendations given in guidelines strictly defines the conditions and the manner in which tests for approval of anchors will be carried out.

Test procedure of anchors can be divided into three types:

- Conformity test for checking the behavior of anchors in extreme conditions
- Test for determination of the load capacity of anchor in exploitation phase
- Test for determination of displacement of the anchor under external loads in exploitation phase

Results from this type of tests represents the behavior of each anchor as well as the type of failure.

In this paper the test procedure and the results obtained from non - standard experimental research of anchors are given. Analyzed anchors are mechanical post – installed anchors which are embedded into non – reinforced concrete blocks and loaded with tension, thus simulating the most unfavorable type of installation and load of anchors.

## 2. EXPECTED BEHAVIOR AND TYPES OF FAILURE FOR ANCHORS LOADED WITH TENSION FORCE

For post – installed anchors loaded with tension force, four types of failure modes are expected and all of the failure modes are characterized with different load – displacement curve in function of different types of factors.

Expected types of failures under external tension load are:

- Concrete cone failure
- Splitting failure
- Pull – out and pull – through failure
- Steel failure

Apart from the type of the anchor, the failure and behavior also depend on installation torque, concrete class, cracked or non- cracked concrete and the way force is applied. Total measured displacement (extraction) of the anchor is compiled of the slip of the anchor, local deformation in concrete zone where the

transfer of the friction load occurs, and the deformation of the anchor itself.

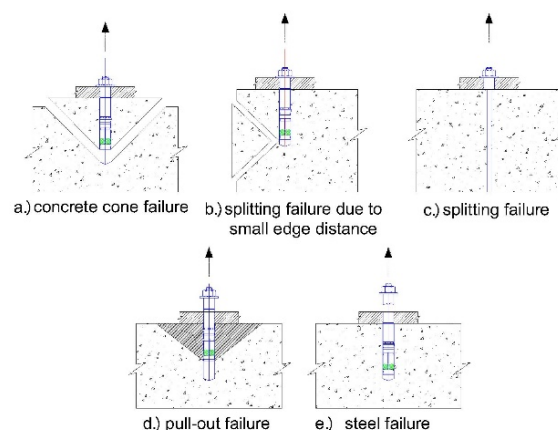

Figure 1. Types of failure due to tension load

Every type of failure occurs after characteristic tension force is reached. Concrete cone failure occurs when full tensile capacity of the concrete is utilised and is characterised by the formation of a “cone” fracture surface in the concrete. This is case when expansion force exceeds or do not fail under force, which is characteristic for pull – through or steel failure. Splitting failure is characteristic failure when anchor is installed near the edge of the concrete embedment or when dimensions concrete cone is limited. When anchor is pulled out of the drilled hole, then pull – out or pull-through failure occurs. In this case anchor may not be damaged and vertical displacement of the anchor is the only parameter which may state to this failure. Pull-through and steel failures are not allowed to happen in some of the approval tests.

## 3. TEST PREPARATION

### 3.1 PREPARATION OF CONCRETE BLOCKS FOR INSTALLATION OF ANCHORS

As mentioned before the pull-out test conducted for mechanical anchors embedded in non-reinforced concrete, presented in this paper, is not standard procedure, which differs from procedures stated in ETAG. Dimensions of concrete blocks for installation of anchors are dictated from minimal conditions prescribed by the manufacturer for each anchor. After analysis of the parameters for each anchor dimensions of concrete blocks are defined. Two types of concrete block with different dimension were made for the experimental research.

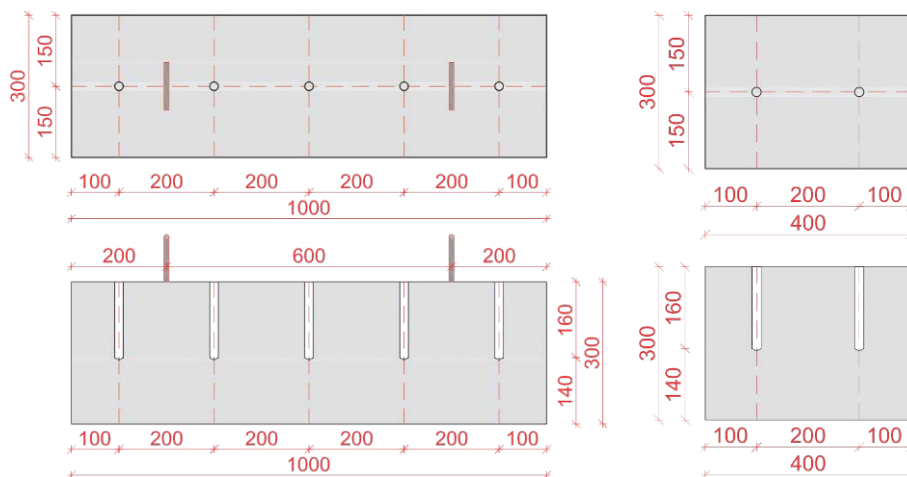

Figure 2. Concrete anchor block type 1 (left) and type 2 (right)

### 3.2 QUALITY CONTROL OF CONCRETE

To control the quality of concrete from which anchor blocks are made, samples from concrete in phase of concreting are taken for further laboratory tests. Samples are taken for cubes with standard dimensions 15/15/15cm in accordance with EN12390-1 (Testing hardened concrete – Part1: Shape, dimensions and other requirements for specimens and molds). According to recommendations, 6 samples are taken in phase of concreting. Samples were stored in controlled laboratory conditions in accordance with EN12930-2 (Testing hardened concrete – Part2: making and curing specimens for strength tests). To determine the class of concrete and compressive strength, 3 cubes were tested after 28 days from concreting the anchor blocks. Obtained results from concrete tests are processed in accordance with EN 13791. From measured results concrete class C25/30 was achieved.

### 3.3 PREPARATION OF CONCRETE BLOCKS FOR DRILLING, INSTALLATION OF ANCHORS AND EQUIPMENT FOR MEASURING TEST RESULTS

In the concrete blocks 8 different types of anchors from 5 different manufacturers were installed. Anchors were divided into group of 5,3 and 2 anchors per block, respecting the installation recommendations.

All parameters for installation of anchors are previously measured and approved. After drilling of the holes, before installation of the anchors, every hole was cleaned from drilling dust.

The electronic equipment is connected to HBM Quantum data acquisition system amplifier, directly connected to computer, with measuring in real time. Results are given in form of vertical deformation of anchor (extraction) in proportion to the applied tension force. Scheme for installation of measuring equipment is shown in Figure 5.



Figure 3. Anchor block type 1



Figure 4. Anchor block type 2

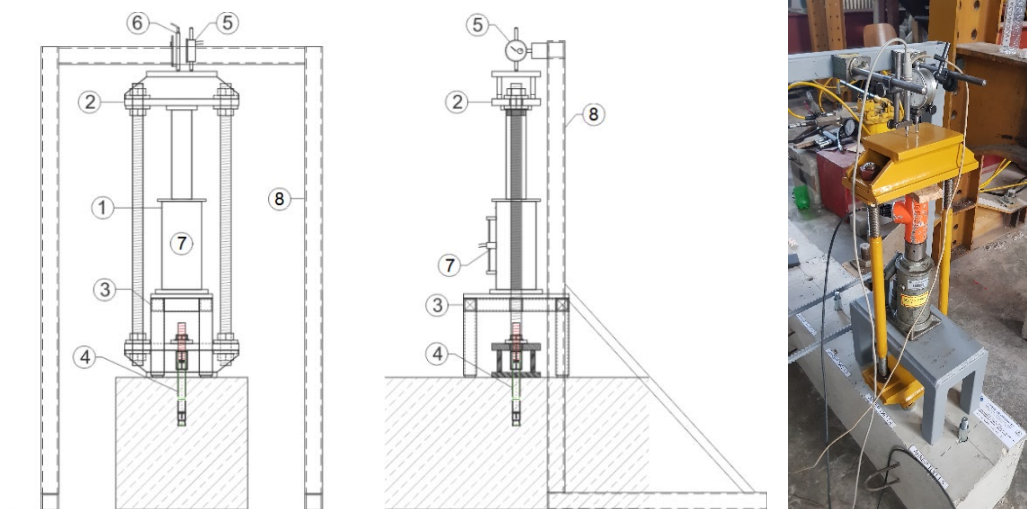

Figure 5. Scheme for installation of the equipment

Where,

- 1) Hydraulic press
- 2) Tension load construction
- 3) Concrete cone support construction
- 4) Installed mechanical anchor
- 5) Electronic deformer (comparator)
- 6) Inductive deformer (comparator)
- 7) Dynamometer
- 8) Support for deformers (comparators)

All of the selected anchors were with similar installation procedure, steel quality, equal diameter and same thread M16, but with different load capacity defined by the manufacturer for the same or similar conditions.

Tension force for the anchor was applied through special designed system with hydraulic press positioned on steel construction which does not affect the concrete cone failure. Application of tension load on anchors was continuously monitored through the electronic dynamometer. Installed anchors were loaded in two phases. In the first phase anchors were loaded to maximum force of 50 kN, defined as the maximal load with excluded safety factor. For the second phase, the anchors were loaded until failure occurs. Measurement of vertical displacement of the anchors was carried out by two positioned deformers (electronic and inductive).

#### 4. RESULTS FROM CONDUCTED PULL-OUT TEST FOR MECHANICAL ANCHORS

With the conducted experimental tests of the mechanical anchors installed in non –

reinforced concrete blocks, the obtained data was used for the analysis of the behaviour of the anchors. All gathered data was processed in form of load – displacement diagrams. The following are the results of phase 2 for each anchor group from the experimental research. In this phase the anchors were loaded until the failure occurs (maximum force of 160 kN).

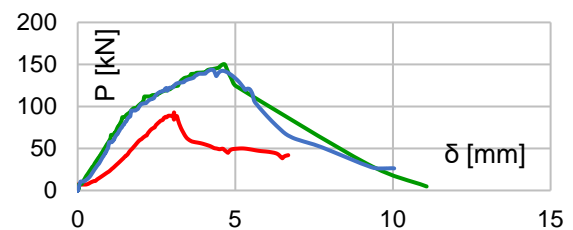

Figure 6. P-δ diagram for anchor type 1

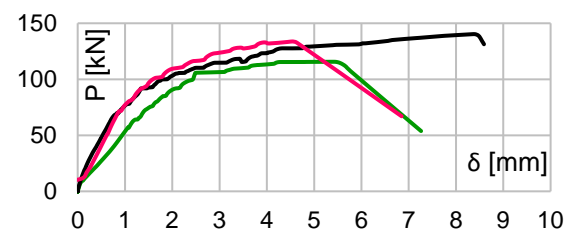

Figure 7. P-δ diagram for anchor type 2

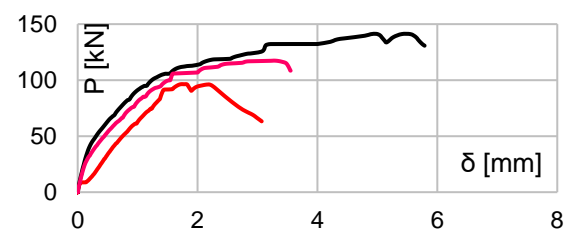

Figure 8. P-δ diagram for anchor type 3



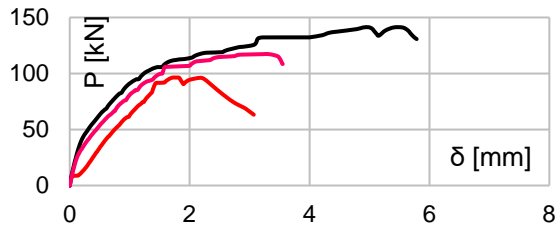

Figure 9. P- $\delta$  diagram for anchor type 4

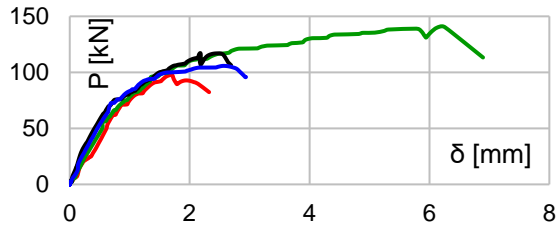

Figure 10. P- $\delta$  diagram for anchor type 5

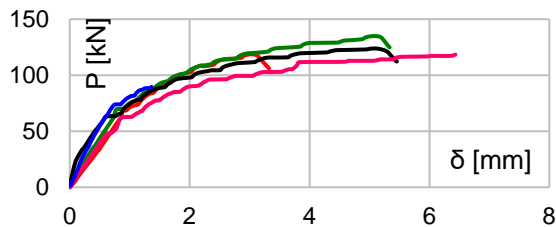

Figure 11. P- $\delta$  diagram for anchor type 6

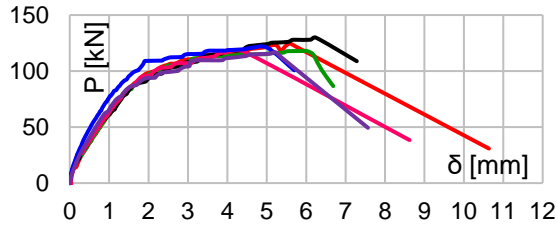

Figure 12. P- $\delta$  diagram for anchor type 7

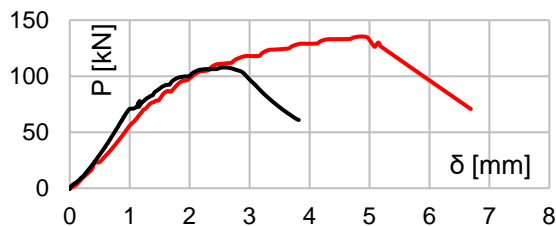

Figure 13. P- $\delta$  diagram for anchor type 8

In all cases of the tested anchors, the failure was splitting of the concrete block. The maximum measured slip, for all the types of mechanical anchors, was between 5.5 to 10.6 mm, as can be seen in the diagrams above.

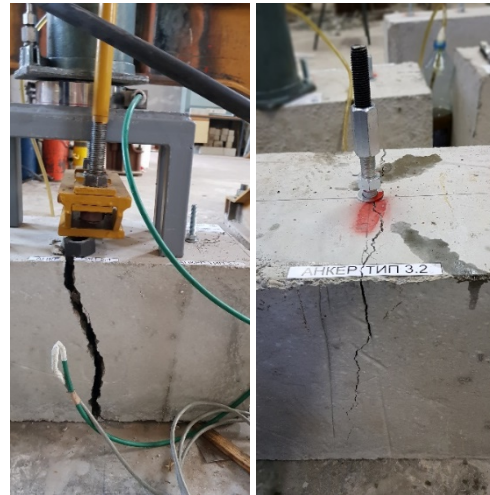

Figure 14. Failure of anchor type 2 and 3

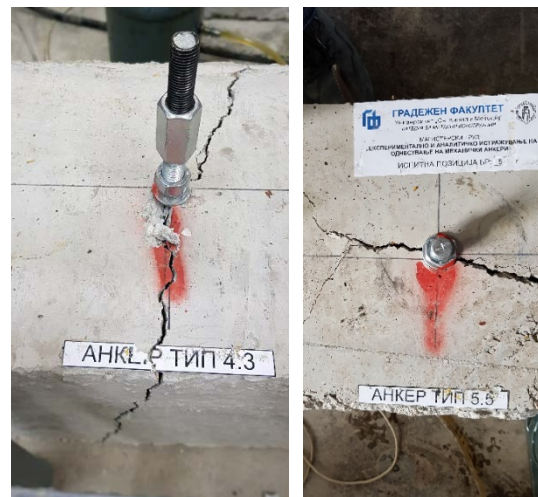

Figure 15. Failure of anchor type 4 and 5



Figure 16. Failure of anchor type 7 and 8

## 5. CONCLUSION

From the occurred data for this experimental research can be concluded that the behavior of the mechanical anchors depends on many different factors, which always vary for each situation.

By obtaining the results and creating the load – displacement diagrams, the behavior of the mechanical anchors as elements for connection gives opportunity for ease of analysis. Conclusions from conducted pull-out test of mechanical anchors are that:

- For mechanical anchors loaded with tension force and installed in concrete elements with minimal allowed dimensions, the failure is always followed with splitting of concrete. This is a result from progressive spread of cracks in the concrete at the zone of load transfer between concrete and anchors mechanism. In this case spreading of cracks in concrete is not limited with reinforcement.
- With the right detailing of reinforcement around anchoring zone, progressive spread of cracks can be prevented and load capacity of the whole detail with anchoring will be significantly increased. In that case different type of failure is expected.
- According to load – displacement diagrams, ductility of this type of failure is satisfactory and meets the minimum requirements for construction connections.
- With further analysis of the results and comparison with the given design and allowed tension loads from the manufacturers for each type anchor, can be concluded that maximum bearing capacity of the anchors is underestimated. This is a result, as previously said, from many different factors which are not always known and from which depends the behavior of the anchors.

## REFERENCES

[1] American Concrete Institute, Evaluating the Performance of Post- Installed Mechanical Anchors in Concrete (ACI 355.2-00), United States of America, 2007.

[2] American Concrete Institute, Qualification of Post- Installed Mechanical Anchors in Concrete (ACI 355.2), United States of America, 2007.

[3] European Organization for Technical Approvals, ETAG 001-Guideline for European Technical Approval of Metal anchors for use in concrete, Part one: Anchors in general, 2013.

[4] European Organization for Technical Approvals, ETAG 001-Guideline for European Technical Approval of Metal anchors for use in concrete, Part two: Torque-controlled expansion anchors, 2012.

[5] European Organization for Technical Approvals, ETAG 001-Guideline for European Technical Approval of Metal anchors for use in concrete, Part three: Undercut anchors, 2012.

[6] European Organization for Technical Approvals, ETAG 001-Guideline for European Technical Approval of Metal anchors for use in concrete, Part four: Deformation-controlled expansion anchors, 2012.

[7] European Organization for Technical Approvals, ETAG 001-Guideline for European Technical Approval of Metal anchors for use in concrete, Part five: Bonded anchors, 2012.

[8] European Organization for Technical Approvals, ETAG 001-Guideline for European Technical Approval of Metal anchors for use in concrete, Annex A: Details of tests, 2012.

[9] European Organization for Technical Approvals, ETAG 001-Guideline for European Technical Approval of Metal anchors for use in concrete, Annex B: Tests for admissible service conditions detailed information, 2012.

[10] European Organization for Technical Approvals, ETAG 001-Guideline for European Technical Approval of Metal anchors for use in concrete, Annex C: Design methods for anchorages, 2012.

[11] European Organization for Technical Approvals, ETAG 001-Guideline for European Technical Approval of Metal anchors for use in concrete, Annex E: Assessment of metal anchors under seismic action, 2012.

[12] European Standard EN 1990-1-1, Eurocode 0: Basis of structural design, 12.2005, European Committee for Standardization.

[13] European Standard EN 1991, Eurocode 1: Actions on structures, European Committee for Standardization.

[14] European Standard EN 1992-4:2015, Eurocode 2: Design of concrete structures – Part 4: Design of fastenings for use in concrete, European Committee for Standardization

[15] European Standard EN 1993-1-8:2005, Eurocode 3: Design of steel structures – Part 1-8: Design of joints, European Committee for Standardization.

[16] European Standard EN 12390-3, Testing hardened concrete, Part 3: Compressive strength of test specimens, 05.2009, European Committee for Standardization.